

CURRIES offers a complete line of flush frames that are available in 18, 16, 14, and 12 gauge cold-rolled or galvanized steel and in 16 or 14 gauge stainless steel. Frames can be knocked down, set up and spot welded at miters, or set up and arc welded at miters and ground smooth. The 12 gauge frames are saw miter welded or saw butt end welded, corner construction only. They are available for either 1-3/8" (35) or 1-3/4" (44) thick doors. CURRIES frames are manufactured for all wall conditions such as masonry, steel stud, wood stud, and poured concrete.

- **Narrow Face Frames**-CURRIES offers pre-engineered, knock-down (KD) flush frames with face dimensions of 1" (25), 1-1/4" (32), 1-1/2" (38), 1-3/4" (44), or 2" (51).
- **Frame Sizes**-Available to match door sizes, in any combination of singles or pairs. Non-standard width or height frames are available on special order.

## M Series/Jamb Depths 3" (76) to 14" (356), 1/8" (3) Increments

### Specifications

Frames shall be M Series as manufactured by CURRIES of Mason City, Iowa. Frames are to be fabricated of either cold-rolled or galvanized steel (as specified) of either 18, 16, 14, or 12 gauge. Joints are to be die-mitered with integral tabs for reinforcement and interlocking of the jambs to the head. 12 gauge frames are saw miter or saw butt end corner construction. Frames shall be knock-down or set-up and welded. Frames shall be thoroughly cleaned and receive an iron phosphate treatment prior to receiving one coat of baked on prime paint. Frames are to be reinforced only for surface mounted hardware, with drilling and tapping to be done in the field by others. Metal plaster guards are to be provided for all mortise cutouts. Minimum requirements for hardware reinforcements are to be as follows: Hinge Reinforcing-7 gauge,

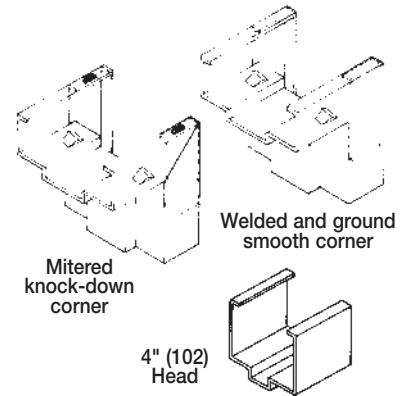

Lock Strike Reinforcing-14 gauge conforming to template requirements and closer reinforcing-14 gauge.

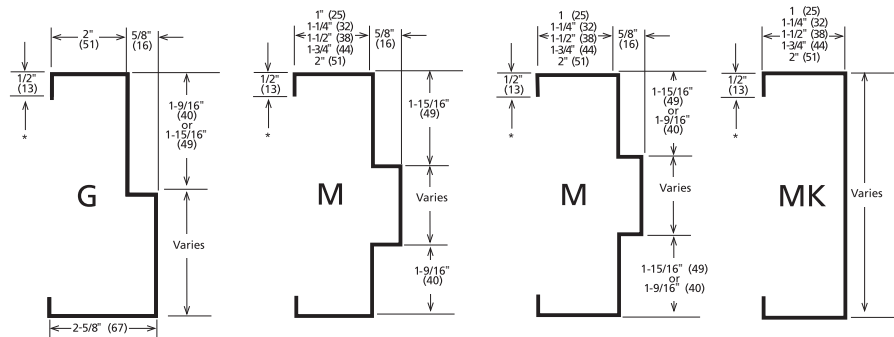

Flush KD  
Gauge 18-16-14  
Jamb depth 3" (76)  
through 14" (356)

Flush KD  
Gauge 18-16-14  
Unequal rabbet  
Jamb depth 4-1/2" (114)  
through 14" (356)

Flush KD  
Gauge 18-16-14  
Unequal rabbet  
Jamb depth 4-7/8" (124)  
through 14" (356)

Flush KD  
Gauge 18-16-14  
Jamb depth 3" (76)  
through 14" (356)

NOTE: 5-3/4" (146) jamb-depth frames have 7/16" (11) back bend.

## Anchors

Here are a few of our standard anchors for masonry, wood studs, steel studs, and solid partitions. Anchors are available either loose or welded in.

